



RISE 5305 Motorized Display Lift Trolley 50 mm/s (black, EU)

Key Benefits

- Height adjustment range of no less than 980 mm
- Movement speed of 50 mm/s for the heaviest screens with QuickRise™
- TÜV and CE certified
- Specially designed foot for extra safety
- Integrated cable management (CIS®)

Screen moved smoothly and safely to the correct height

A RISE 5305 motorized display lift trolley is suitable for displays of up to 86" and 120 kg max. The lift raises the screen smoothly, quickly and safely at a speed of 50 mm/s with QuickRise™. With a 980 mm travel range the lift is suitable for both very low and high positions. The top-down assembly ensures quick installation. We offer a 5 year guarantee. Safety first Vogel's display lift systems comply with the highest international safety standards of TÜV and CE (UL and GS pending).

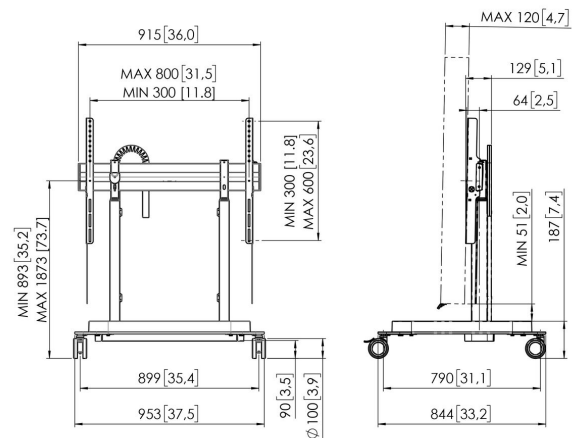



RISE 5305 Motorized Display Lift Trolley 50 mm/s (black, EU)



Specifications

Article number (SKU)	7353050
Colour	Black
EAN single box	8712285358029
Height	1205
Width	955
Depth	846
TÜV certified	Yes
Guarantee	5 years
Min. screen size (inch)	65
Max. screen size (inch)	86
Max. weight load (kg)	120
Certifications	CE
Max. distance to floor - center display (mm)	1867
Max. horizontal hole pattern (mm)	800
Max. screen size (inch)	86
Max. vertical hole pattern (mm)	600
Min. distance to floor - center display (mm)	887
Min. horizontal hole pattern (mm)	300
Min. screen size (inch)	65
Min. vertical hole pattern (mm)	300
Motorized	Yes
Travel	980

VOGEL'S HOLDING BV (©)

All rights reserved.
Subject to printing errors,
technical and price
amendments.

Date: 2022-06-09



Vogel's. For Sure.