

Vision Edgeless

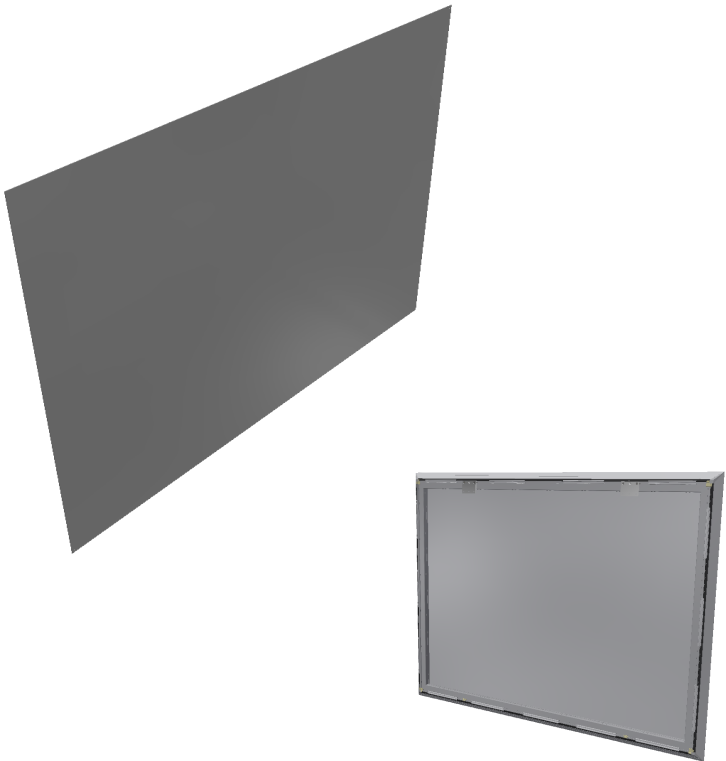

Thank you for choosing a Euroscreen® to be part of your AV installation. We hope it will bring you many hours of entertainment and/or education depending on your preference. Please read through the manual completely before installation and usage.

Tack för att ni valt en Euroscreen® som en del i er AV-installation. Vi hoppas den kan ge er många timmar av underhållning och/eller utbildning, beroende på aktivitet. Läs igenom hela manualen innan installation och användning.

Overview / Översikt

Case / Kasset

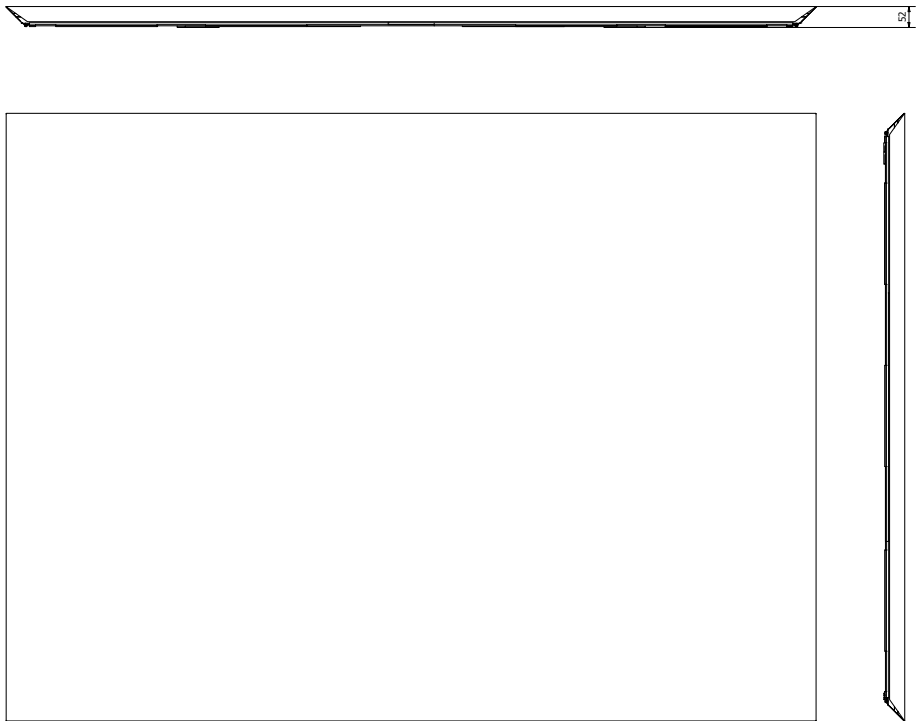

fig 1

Edgeless bracket / Edgelesskonsol

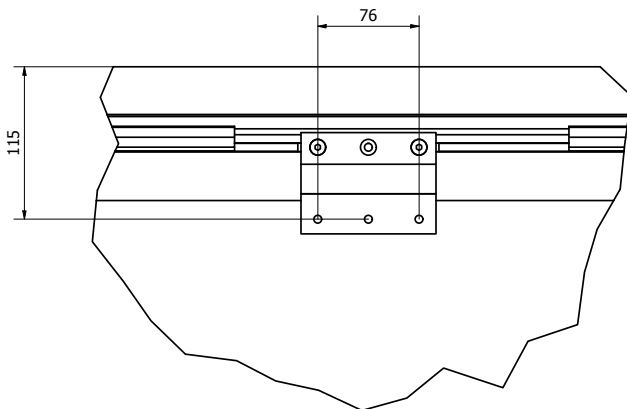

fig 2

Overview / Översikt

UK: insert corner pieces into the frame pieces. Remember to add the squared nuts into their slot before assembling all the corners. There should be two nuts for each bracket (in total 4pcs) in the top extrusion. If there is a center support there shall be one extra nut in both the top and bottom extrusions.

Lock and tighten the corners (fig 4).

Attach the brackets evenly on the top piece to match the fastening points for the brackets mounted on the wall (fig 5).

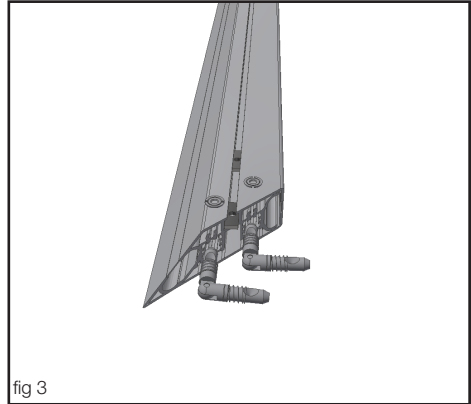

SE: För in hörndelarna i ramprofilerna. kom ihåg att föra in fyrkantsmutterarna i sitt spår innan profilerna sätts ihop. Där skall vara 2st muttrar per konsol (totalt 4st) i den övre ramdelen.
Om det skall monteras ett mittsteg så behövs det en extra mutter i både den övre och den nedre profilen.

Skruva åt hörnen (fig 4).

Fäst konsolerna jämnt fördelat på toppprofilen så att de passar med fästpunkterna för konsolerna som skall skruvas fast på väggen (fig 5).

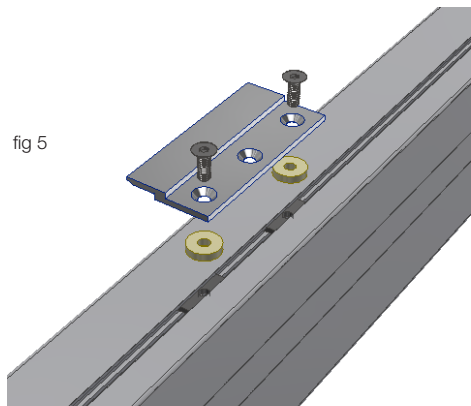
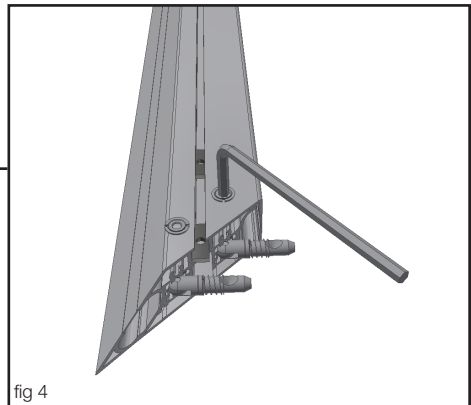

UK: OPTIONAL

Attach center support in top and bottom (fig 6).

Unroll the screensurface, viewing side down, on a clean and smooth surface. Put frame carefully on top. Frame corners shall reach surface edges (fig 7). Slide hook-extrusions onto the screen surface (fig 8).

Fasten hooks into the groove (see fig 9).

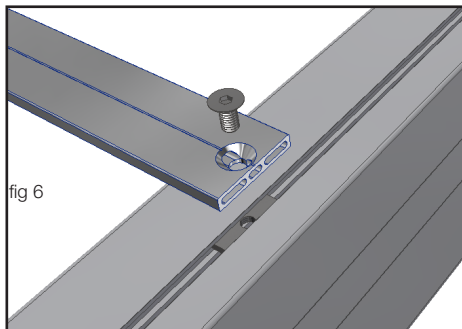

fig 6

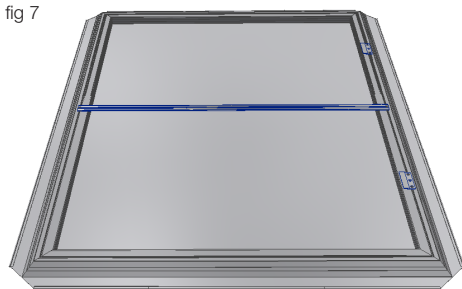

fig 7

SE: OPTION

Fäst mittstaget i både topp och botten (fig 6).

Rulla ut dukmaterialet med bildsidan nedåt på en ren och slät yta. Lägg ramen försiktigt ovanpå. Hörnspetsarna skall nå ut till dukkanten (se fig 7). För på haklister runt om (fig 8).

Fäst haklisterna i spåret (se fig 9).

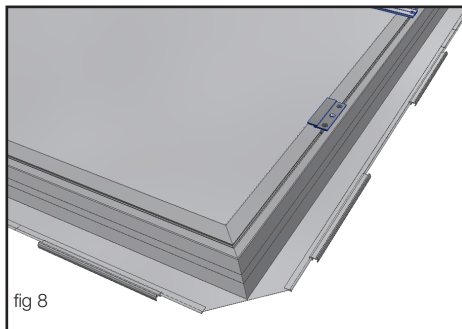
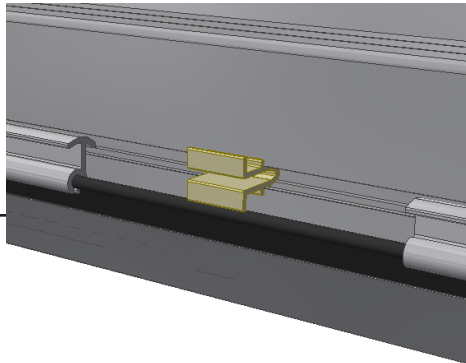

fig 8



EN: Add bottom distance piece (see fig 10).



SE: Montera den nedre distansen (se fig 10).

fig 10

Wall mount / Vägghmontering

Wall bracket / Vägghkonsol

fig 11

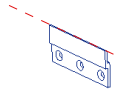

EN: USE FASTENERS INTENDED FOR THE ACTUAL SURFACE. Try to level them up as good as possible, using spirit level or laser guide (fig 11). Sideways spacing isn't crucial as they can slide sideways but we recommend that you try to even them out along the width.

Please note that center of the screw is 115mm from top edge of screen (fig 12).

SE: ANVÄND FÖR UNDERLAGET AVSEDD SKRUV. Försök att linjera de bägge konsolerna så horisontellt som möjligt med hjälp av vattenpass eller lasermätare (fig 11).

Exakt positionering i sidled är inte nödvändig då ramen kan glida på konsolerna men vi rekommenderar att konsolerna förselas ut över bredden.

Notera att skruvhålet hamnar 115mm under överkant dukyta (fig 12).



fig 12

EN: Hang the frame onto the wall so that the brackets on the wall and the frame interlock (fig 12).

SE: Häng ramen på väggen så att fästena på vägg och ram hakar i varandra (fig 12).

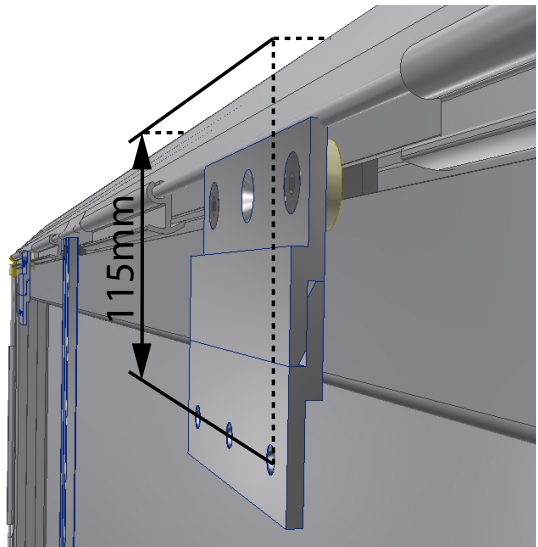

Conformity of regulations

Draper Europe AB manufactures AV equipment within the brand Euroscreen®. These products are controlled and certified by the below listed regulations.

REACH

Registration, evaluation, authorisation and limitation of chemicals. Regulation (EC) No 1907/2006 of the European Parliament and of the European Council concerning the Registration, Evaluation, Authorisation and Restriction of Chemicals (REACH).

All screen surfaces of Euroscreen® projection screens are approved by the REACH regulation.



ECHA

European Chemicals Agency (ECHA) gathers information on the properties of manufacturers and importers chemical substances, which will allow their safe handling, and to register the information in a central database.

Euroscreen® projection screens are printed with colours containing the following components:

CAS 1333-86-4, CAS 112-36-7, CAS 96-48-0, CAS 143-24-8, CAS 1559-34-8, CAS 2687-91-4, CAS 111-90-0, CAS 34590-94-8 and CAS 126-86-3. These are all approved by ECHA.



RoHS

Restriction of Hazardous Substances Directive (RoHS) directive restricts the use of six hazardous materials in the manufacture of various types of electronic and electrical equipment.

All electrical devices used in Euroscreen® products are RoHS certified.



WEEE

The Waste Electrical and Electronic Equipment Directive (WEEE Directive) is the European Community directive 2002/96/EC on waste electrical and electronic equipment (WEEE) which, together with the RoHS Directive 2002/95/EC, setting collection, recycling and recovery targets for all types of electrical goods.

Applicable Euroscreen® products are labeled with the WEEE symbol.



FR2000

FR2000 is an integrated management system for quality, environment, competence enhancement, health and safety. This systems is derived from; ISO 9001, ISO 14001, SS 62 40 70, the Swedish work environment authority regarding systematic environmental progress, and the Swedish rescue services agency regarding systematic fire safety, SRVFS 2004:3.

Draper Europe AB is certified by FR2000 since 2010.



FTI

Producers responsibility for recycling of packaging material is regulated by SFS 2006:1273. The recycling process of packaging material is handled for its members by a central organization called FTI.

Draper Europe AB is a member of FTI.



Declaration of Conformity

Draper Europe confirms that Euroscreen® Electric meets Low Voltage Directive 2006/95/EG & EMC Directive 2004/108/EC. This is a EN61140 Class I product with internal separation instead of protective conductor (EN61140 7.2.2 Note 2).

Euroscreens® are CE-approved.



Draper Europe AB / Västervallvägen 6 / 302 50 Halmstad
Tel: 035-14 42 90 / Fax: 035-14 42 91



970208

8